

# RADIX SCANNER

EXCELLENCE IN WELD INSPECTION

X  
I

D

A

R

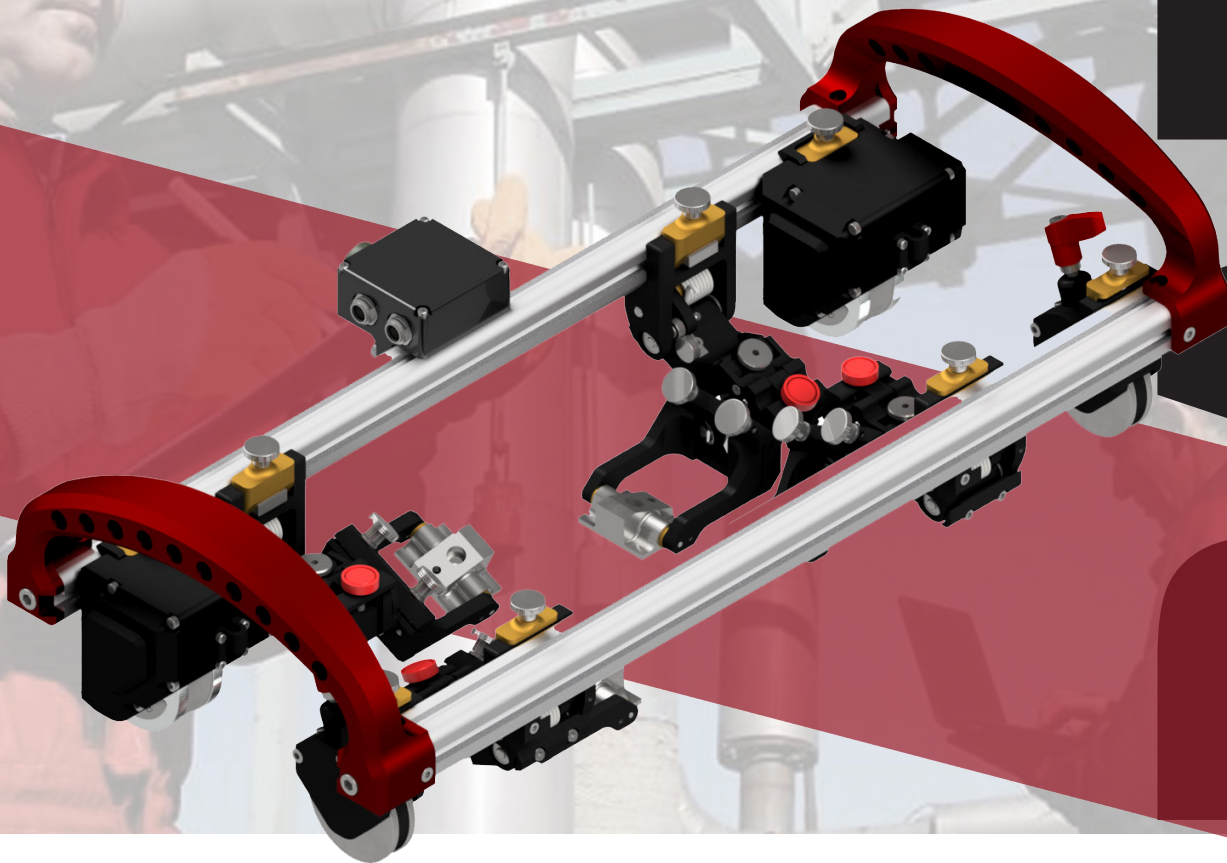

## Discover the Pinnacle of Scanning Technology

The Radix Scanner excels in delivering detailed and accurate inspections thanks to its cutting-edge design and robust functionality. Ideal for challenging applications, from high-temperature surfaces to rugged terrain, the Radix ensures consistent performance with its state-of-the-art components. Whether you're scanning for weld integrity, corrosion analysis, or material defects, the Radix provides the precision you need to maintain the highest standards of safety and quality.

# RADIX SCANNER WELD INSPECTION



Discover the pinnacle of scanning technology with the Radix Scanner from ScanTech Instruments. Engineered for precision and reliability, the Radix weld scanner is your solution for advanced non-destructive testing in diverse industrial environments.

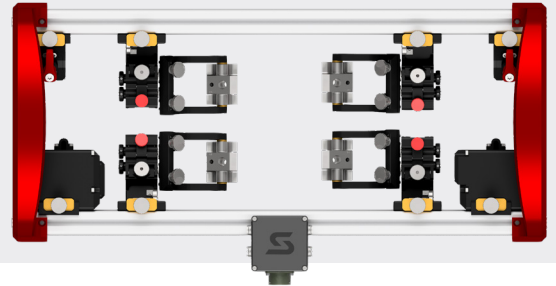

## TECHNICAL INFORMATION

### SPECIFICATIONS

Weight (with standard probe)	9 lbs	4.1 kg
Speed (@ full load)	6 in/sec	150 mm/sec
Scanning Capabilities	360-degree	Rotational scans
Power Requirements	24V DC	
Compatibility	Works with all standard UT and phased array probes	

### Minimum Diameters:

ID Standard Probe Assembly	12 in	304 mm
OD for Axial Scans	4.25 in	107 mm

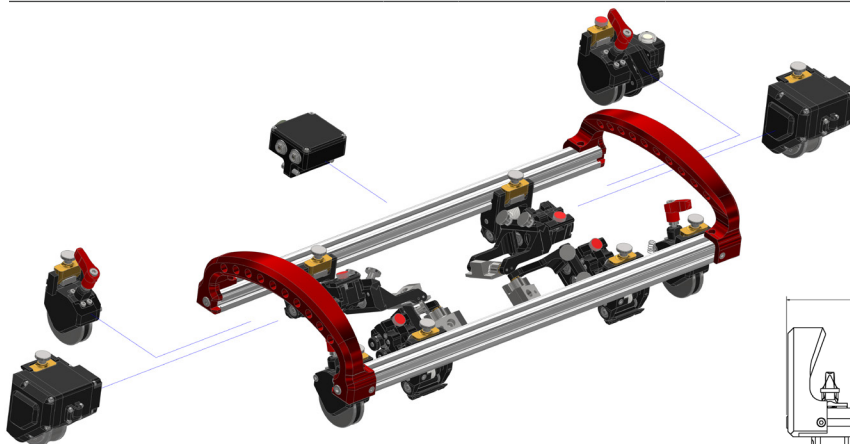

## FEATURES

- ✓ **Adaptive Controls:** User-friendly interface with customizable settings for varied testing conditions.
- ✓ **Enhanced Mobility:** Lightweight design with an integrated handle for easy transport and positioning.
- ✓ **Robust Construction:** Manufactured with high-grade materials to withstand harsh industrial environments.
- ✓ **Advanced Imaging:** Incorporates high-resolution sensors for clear, detailed images under any conditions.

