

# APEX SCANNER

MODULAR UNIVERSAL PLATFORM



## Precision for Real-World Scanning

The APEX Modular Scanner Platform is engineered to tackle the toughest industrial inspections with precision and ease. Its adaptable design allows it to perform high-quality scans across multiple applications, delivering reliable data in even the most challenging environments. Whether you need manual or automated operation, APEX ensures top-tier performance, offering the ultimate flexibility for your inspection needs.



# UNIVERSAL SCANNER PLATFORM



SCAN TO SEE IN  
ACTION!

The Apex Scanner boasts compact dimensions with a length of 10.5 inches, width of 10.8 inches, and height of 4.95 inches, making it highly portable. Weighing just 19 lbs, it features robust drive units with speeds up to 36 inches per second and high torque output. The scanner includes advanced probe mechanisms for increased stability and environmental resistance, ensuring reliable performance in industrial conditions.



## TECHNICAL INFORMATION

### SPECIFICATIONS

Length	12 in	305 mm
Width	9 in	229 mm
Height	8.5 in	216 mm
Weight (with standard probe)	13 lbs	5.9 kg
Speed (@ full load)	5.5 in/sec	140 mm/sec
Tractive Pull Force	>65 lbf	145 N
Magnetic Force	>300 lbf (all wheels)	>850 lbf (Peak - all wheels)
Minimum Diameters:		
Minimum OD	12 in	305 mm
Minimum OD	6 in	152 mm

Main Body

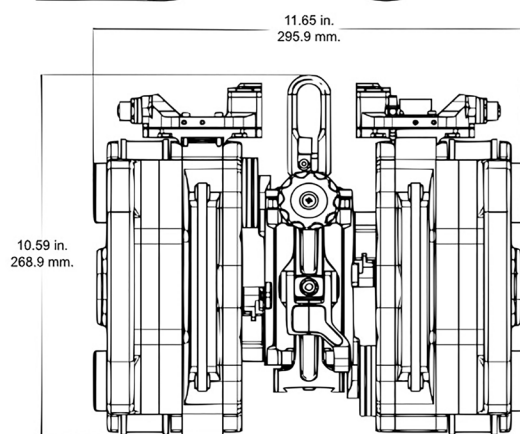
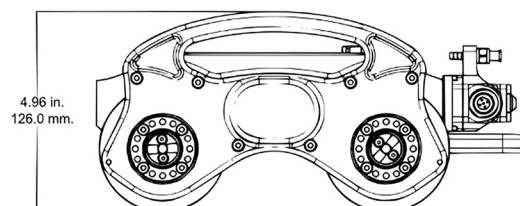

Crawler Weight: 22.0 lbs

## FEATURES

- ✓ **Modular Design:** Easily configurable for both manual and automated scanning.
- ✓ **Advanced Probe Technology:** Ensures precise ultrasonic data with optimal surface contact.
- ✓ **High Torque Drive Units:** Delivers powerful performance in tough inspection environments.
- ✓ **Versatile and Portable:** Designed for easy deployment with modular adaptability for diverse applications.